

Experiment Report Form

The double page inside this form is to be filled in by all users or groups of users who have had access to beam time for measurements at the ESRF.

Once completed, the report should be submitted electronically to the User Office using the **Electronic Report Submission Application:**

<http://193.49.43.2:8080/smis/servlet/UserUtils?start>

Reports supporting requests for additional beam time

Reports can now be submitted independently of new proposals – it is necessary simply to indicate the number of the report(s) supporting a new proposal on the proposal form.

The Review Committees reserve the right to reject new proposals from groups who have not reported on the use of beam time allocated previously.

Reports on experiments relating to long term projects

Proposers awarded beam time for a long term project are required to submit an interim report at the end of each year, irrespective of the number of shifts of beam time they have used.

Published papers

All users must give proper credit to ESRF staff members and proper mention to ESRF facilities which were essential for the results described in any ensuing publication. Further, they are obliged to send to the Joint ESRF/ ILL library the complete reference and the abstract of all papers appearing in print, and resulting from the use of the ESRF.

Should you wish to make more general comments on the experiment, please note them on the User Evaluation Form, and send both the Report and the Evaluation Form to the User Office.

Deadlines for submission of Experimental Reports

- 1st March for experiments carried out up until June of the previous year;
- 1st September for experiments carried out up until January of the same year.

Instructions for preparing your Report

- fill in a separate form for each project or series of measurements.
- type your report, in English.
- include the reference number of the proposal to which the report refers.
- make sure that the text, tables and figures fit into the space available.
- if your work is published or is in press, you may prefer to paste in the abstract, and add full reference details. If the abstract is in a language other than English, please include an English translation.



Experiment title: Coherence matched microfocusing of hard x-rays with blazed zone plates

Experiment number:
MI-638

Beamline:
ID13

Date of experiment:
from: 13.2.2003 to: 17.2.2003

Date of report:
21.10.2003

Shifts:
12

Local contact(s): Dr. Manfred Burghammer

Received at ESRF:

Names and affiliations of applicants (* indicates experimentalists):

Bernd Nöhammer *

Dr. Christian David *

Ana Diaz *

Dr. Timm Weitkamp*

Paul Scherrer Institut
Laboratory for Micro and Nanotechnology
CH-5232 Villigen -PSI
Switzerland

Report:

The intention of this experiment was to use two blazed linear fresnel lenses with ultra high efficiencies in a coherence matched geometry to produce a intense microfocus spot. The lenses had been tested in a previous beam time (MI-563), and they showed diffraction efficiencies of up to 65% in the 10-15 keV region. Figure 1 depicts the used linear Fresnel lenses and the setup used.

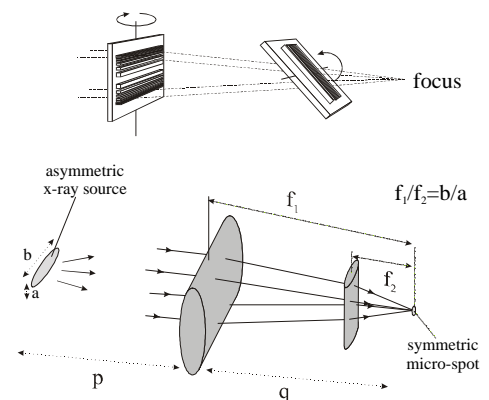
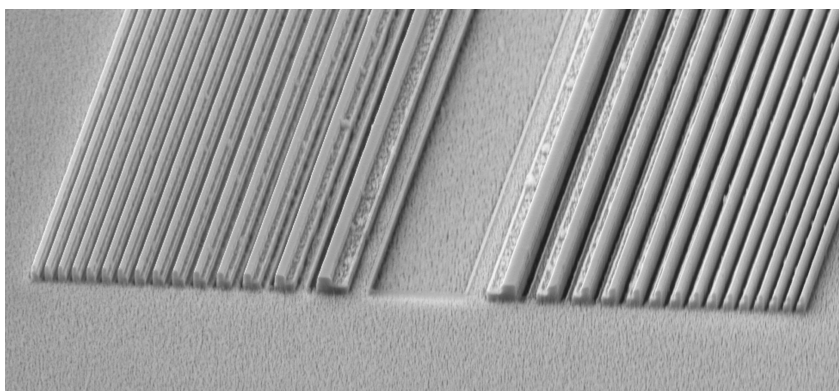

Fig. 1: SEM image of a linear 4-level Si FZP with 800 nm outermost zone width (left). By a tilting of a linear FZP with respect to the x-ray beam, the diffraction efficiency can be tuned to maximum. Two such lenses are capable of two-dimensional focusing to give a spot (top right). By choosing an appropriate ratio of the lenses focal lengths, the aperture can be matched to the spatial coherence lengths of the source (lower right).

We used a beam energy of 12.7 keV. The tested combination of lenses had the following parameters:

- For vertical focusing: 200 μm aperture, 800 nm outermost period, 750 mm focal length, 87° tilt
- For horizontal focusing: 50 μm aperture, 800 nm outermost period, 187 mm focal length, 87° tilt

The efficiency of the vertically focusing lens was measured to be 62%. Using two of these lenses in series thus gave a total efficiency of close to 40%. The spot size of the lens-combination was tested in two different ways:

- We recorded the tantalum fluorescence signal obtained by scanning a Ta grating with variable grating constant across a focal spot. If the width of the micro-focus is significantly smaller than the grating period this leads to strong variations of the fluorescence signal, depending on whether the binary tantalum grating is fully hit by the focal spot or not. Going to smaller grating periods (regions in the left part of the figure) these oscillations gradually decrease and finally cease, meaning that the according grating period cannot be resolved any more. Figure 2 shows the recorded signal and the derived modulation transfer function (MTF). The MTF cuts off at about 2 μm in horizontal and vertical direction.

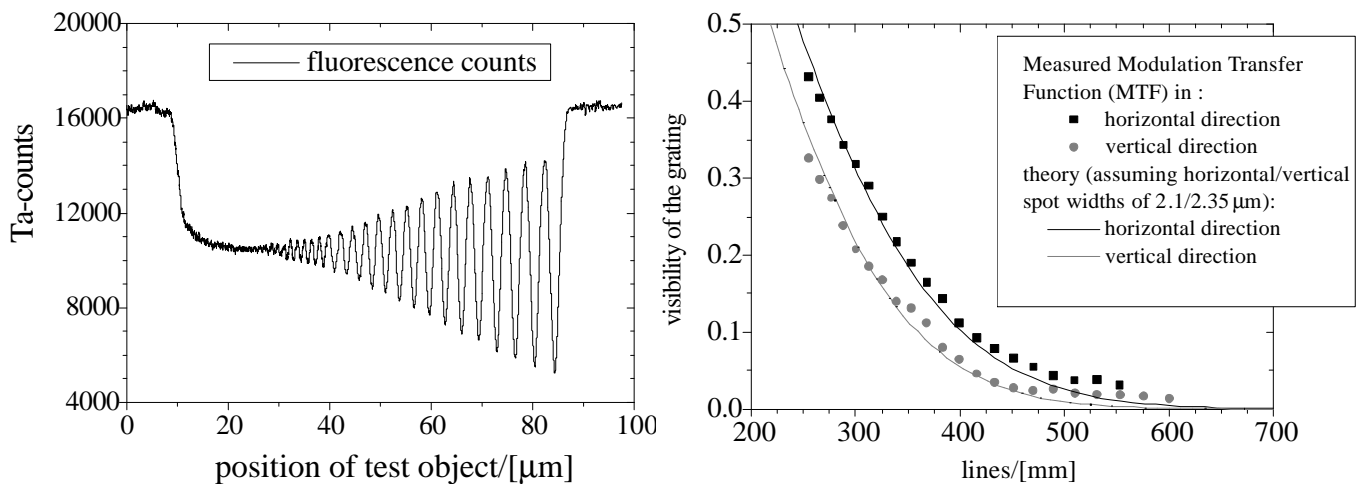

Fig. 2: Measured fluorescence signal (left) and derived visibility of a binary tantalum grating (right).

- As a second test we performed knife edge scans over a Ta edge while recording the Ta fluorescence. The resulting data are shown in Fig. 3. A FWHM of 1.9 μm can be derived.

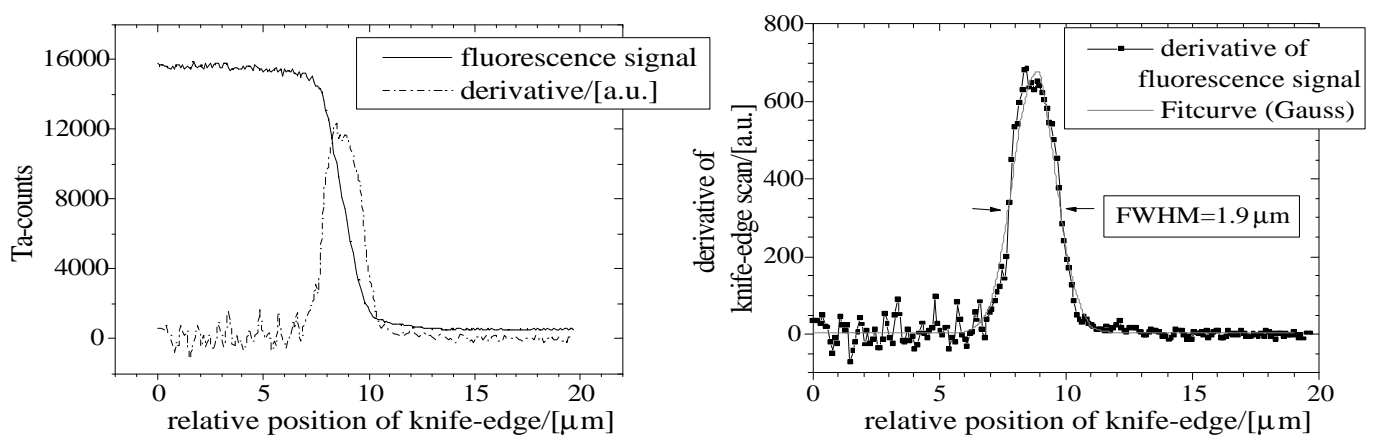

Fig. 3: Fluorescence signal obtained by scanning a knife-edge across a focal spot.

The focal spot size is approx. twice larger than expected. We assume that instabilities of the beam line are the cause for this. Nevertheless, the lens combination gives 2 μm , a gain of 1000 and a divergence of only 270 μrad , which makes it an excellent device for μSAXS experiments. The device is now available at ID13 for user experiments.

We would like to thank M. Burghammer, J. Meyer, L. Lardiere, and L. Claustre for their excellent support.