

**Experiment title:**Pressure induced phase transitions
in semi-crystalline polymers**Experiment
number:**

SC-294

Beamline:

ID1 1-B12

Date of Experiment:from: **26/6/97** to: **28/6/97****Date of Report:****17/9/97****Shifts:**

6

Local contact(s):

H. Graafsma

Received at ESRF :

02 MAR. 1998**Names and affiliations of applicants** (*indicates experimentalists):**U. Goechel***, **J.G.P. Goossens***, **F.H.M. Swartjes*** and **H.E.H. Meijer**,Eindhoven University of Technology, Centre for Polymers and Composites,
P.O. Box 513,5600 MB Eindhoven, The Netherlands**Report:**

Time-resolved 2-D WAXD studies were performed to describe crystallization and crystallite orientation under elongational flow conditions,

An elongational flow cell approved in Synchrotron experiments at the DESY in Hamburg¹ was used. The flow cell consisted of a 9.5 mm diameter cylindrical reservoir of 160 mm in length and a slit shaped die of 1.5 x 2 mm² and 10 mm in length (*Figure 1*).

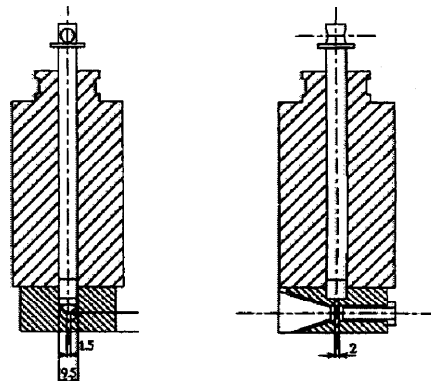

Figure 1: Flow cell for elongational flow

Polymer preforms were inserted in the cylindrical reservoir prior to heating towards a temperature of a few degrees above the melting temperature. After annealing at the chosen temperature for about 60 min, the melt was forced by a piston through the capillary within 60 to 300 s. Two different polymer materials, isotactic polypropylene (iPP) and high density polyethylene (HDPE) were chosen for investigations in the temperature range from 145 to 157 °C and 170 to 180 °C, respectively.

The HDPE with $M_w = 210$ kg/mol revealed a reflection at $2\theta = 9.05^\circ$ using $\lambda = 0.757$ Å corresponding to amorphous bulk material (Figure 2). The peak position does not change with temperature and is equal for both the quiescent and the forced melt (flow rate: 1.48 to 4.04 mm/s). An ordering effect is seen in changes of the peak intensity and half width as well. The weak equatorial crystalline reflection in form of a small shoulder might correspond to the orthorhombic (110) reflection. The small arc characterizes a very high orientation in flow direction.

For iPP with $M_w = 365$ kg/mol significant crystallization and crystallite orientation was detected at 170 and 172 °C using a flow rate from 1.18 to 4.96 mm/s (Figure 3). At 170 °C a growth and arcing of the equatorial (110) and (040) reflections is detected.

Conclusions:

In situ 2-D WAXD studies have revealed crystallization and orientation of HDPE and iPP under conditions of elongational flow. The morphological changes occur in a narrow temperature window and they strongly depend on e.g. flow rate, molecular weight and distribution. Further experiments are needed to describe the flow-induced crystallization in more detail.

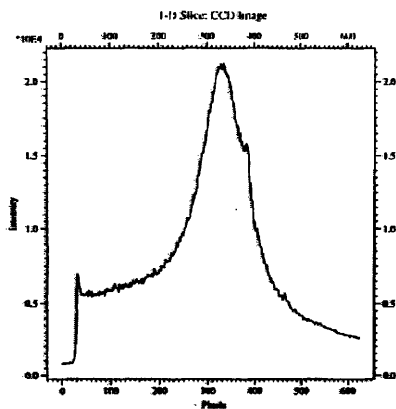

Figure 2: HDPE, 145 °C

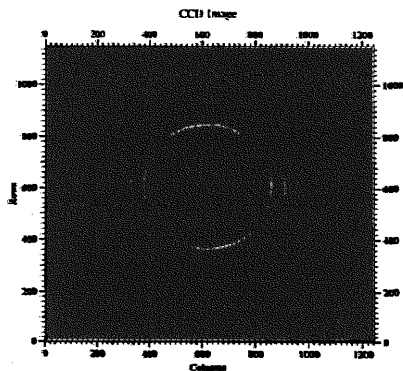

Figure 3: iPP, 170 °C, flow vertical

Reference

[1] H.M.M. van Bilsen, H. Fischer, H.W.H. Kolnar and A. Keller, *Macromolecules*, 28, 8523 (1995)