

	<b>Experiment title:</b> EXAFS study of well-defined metal nanoparticles on planar supports	<b>Experiment number:</b> CH-1699
<b>Beamline:</b> ID26	<b>Date of experiment:</b> from: 13/05/04                                  to: 17/05/04	<b>Date of report:</b> 23/08/04
<b>Shifts:</b> 12	<b>Local contact(s):</b> O. Safonova	<i>Received at ESRF:</i>
<b>Names and affiliations of applicants (* indicates experimentalists):</b> Dr. Norbert Weiher* (weiher@chem.ethz.ch) Dr. Jeroen van Bokhoven* (jeroen.vanbokhoven@chem.ethz.ch) Eveline Bus* (eveline.bus@chem.ethz.ch) Prof. Dr. Roel Prins (prins@chem.ethz.ch) <i>Affiliation for all applicants:</i> Institute for Chemical and Bioengineering - ETH Hnggerberg Building HCI - 8093 Zrich - Switzerland		

### Introduction and experiment description

Interest in metal clusters range from aspects of fundamental physics to applications of these systems in catalysis. Investigations concerning the electronic properties of such clusters show e.g. that the electronic structure varies strongly with cluster size, if the particles are sufficiently small [1]. This implies that reactive molecules like H<sub>2</sub> or CO interact different with clusters than with bulk materials. In catalysis, metal nanoparticles are usually deposited on porous supports to keep them highly dispersed. Although these particles are the active centers in the catalytic mechanism, the support strongly influences selectivity and activity [2,3]. Catalysts usually are investigated *in situ* to obtain information on their structure under catalytic relevant conditions. Our approach is to study small gold clusters on planar supports as model systems, thus focusing on the specific interaction of reactive gases with the metal clusters. Using SiO<sub>2</sub> as support, the support information is minimized. The general questions addressed in this proposal were whether XAS experiments are feasible in these model systems and if so, to elaborate on the interaction of hydrogen with these monodispersive particles.

For the specified experiments, an *in situ* EXAFS cell (Fig. 1) was designed to meet the following conditions: (a) measurements of flat supports under grazing incidence angle, (b) *in situ* gas treatments, on line analysis of the gas products with a sensor close to the sample

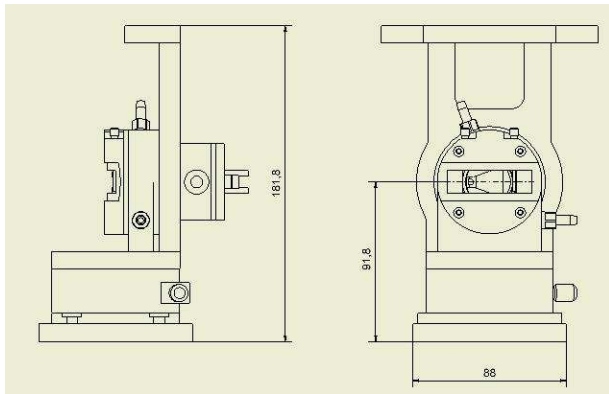

Figure 1: Fluorescence XAS cell used in the experiments

surface, (c) temperature range from 77 to 670 K. All windows and the sample holder are made of aluminium.

The samples (see ref. [4] for synthesis conditions) used were flat silica wafers (sized 15x15 mm<sup>2</sup>) with gold coverages of 0.05 and 0.3 monolayers. A 13-element germanium detector was used for data acquisition.

Reasonable data quality has been achieved within ~8 hours of measurement per spectrum. The samples were measured under the following conditions: (a) He flow of 20 ml/min, room temperature, (b) after treatment with flowing H<sub>2</sub> (5% in He) at 373 K for one hour, in a flow of H<sub>2</sub>/He of 20 ml/min (measured at RT).

### Data evaluation

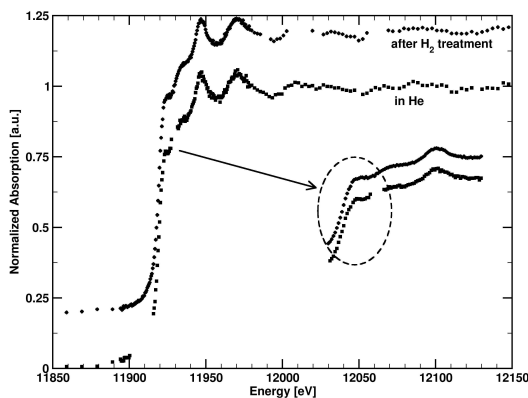

Figure 2: XANES spectra for a coverage of 0.3 ML

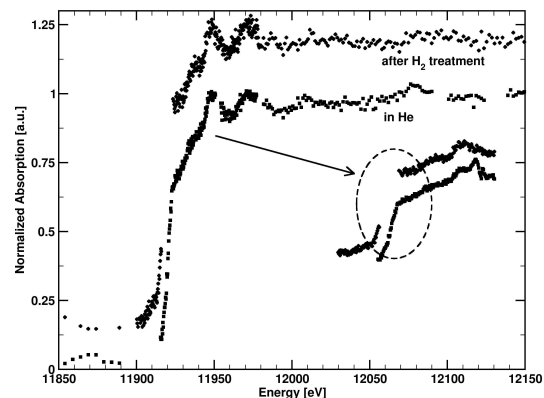

Figure 3: XANES spectra for a coverage of 0.05 ML

Fig. 2 and 3 show the XANES region of the Au L<sub>3</sub> edge for a gold coverage of 0.3 ML and 0.05 ML, respectively. The data are identical within noise level. Analysis was difficult due to the presence of glitches arising from the crystallinity of the support. For some spectra, these glitches resided near the position of the absorption edge (fig. 3), with their removal leading to loss of important spectroscopical information. EXAFS analysis of the first backscattering shell shows the increase of the coordination number from 11.61 to 12.00, with all other fitting parameters lying at reasonable values ( $\Delta E=4.64, 6.26$  eV;  $\Delta R=-0.048, -0.038$  Å;  $\sigma^2=0.008, 0.009$  Å<sup>2</sup> for the fits before and after H<sub>2</sub> treatment), when comparing the sample covered with 0.3 ML before and after treatment in H<sub>2</sub>. The CN of 11.61 is in good agreement with AFM/TEM results. The slight increase is not significant concerning the statistics, but could

point at shape change of the particles; sintering is not likely to happen at the temperature of the treatment. For the sample covered with 0.05 ML of gold, an EXAFS analysis was impossible due to the poor S/N ratio already in the first few  $\text{\AA}^{-1}$ .

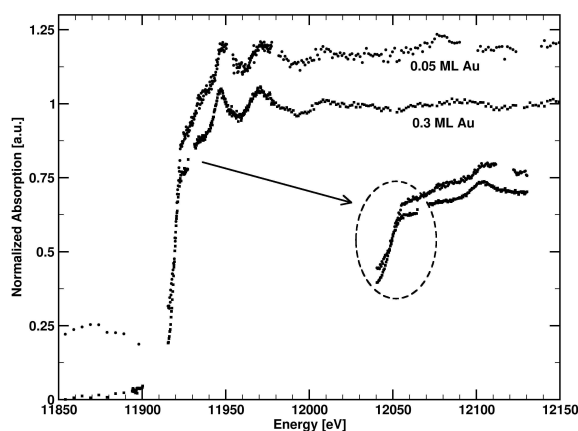

Figure 4 shows the difference in the XANES of both investigated samples before treatment with hydrogen. As before, the XANES region exhibits no differences between the two coverages. Also, a comparison with a spectrum of gold foil exhibits no differences.

Figure 4: Comparison of the XANES region of the investigated model systems

### Summary

The experiments conducted here show that it is possible to measure gold XANES spectra on model catalysts with extreme low loading. However, the metal-hydrogen interaction, which manifests itself as an increase in intensity  $\sim 5$  eV above the absorption edge (region encircled in all spectra shown), could not be detected, which might have different reasons. In the case of the sample with a coverage of 0.3 ML, the particles can be too big to detect the metal-hydrogen interaction. For the second sample, the S/N ratio was poor. The spectral quality does hardly allow to look for subtle changes in the spectra. Nevertheless, the method is promising in case data quality can be further enhanced and particle size is further reduced. Future experiments will include (a) using different reactive gases ( $\text{CO}$ ,  $\text{O}_2$ ), which are easier to detect due to the higher backscattering factors and (b) using samples with even lower particle sizes. Various supports (e.g.,  $\text{Al}_2\text{O}_3$ ,  $\text{TiO}_2$ , glassy  $\text{SiO}_2$ ) will be applied. Summarizing, we have proven that XAS investigations are feasible on the model systems described here. As has been seen from the analysis of the 0.3 ML sample, EXAFS provides information about the particles under different atmospheres, with the results being in good agreement with other characterization techniques.

### References

- [1] A. Howard, D.N.S. Clark, C.E.J. Mitchell, R.G. Egdell, V.R. Dhanak, *Surf. Sci.* **518** (2002) 210
- [2] D.C. Koningsberger, M.K. Oudenhuijzen, J. de Graaf, J.A. van Bokhoven, D.E. Ramaker, *J. Catal.* **216** (2003) 178
- [3] T. M. Tri, J. Massardier, P. Gallezot, B. Imelik, *Stud. Surf. Sci. Catal.* **11** (1982) 141
- [4] J.P. Spatz, C. V.Z.-H., S. Mössmer, M. Möller, *Adv. Mater.* **14** (2002) 1827