



DUBBLE – EXPERIMENT REPORT

Beam time number: 26-02-866		File number: 79802
Beamline: BM26-B	Date(s) of experiment: 03 may 2018 - 07 may 2018	Date of report: 08 May 2019
Shifts: 9	Local contact(s): Daniel Hermida Merino	

**1. Who took part in the experiments?**

Fabio Paolucci<sup>1</sup>, Prakhyat Hejmady<sup>1</sup>, Jessica Pepe<sup>1</sup>

Affiliation:

1. Polymer Technology Group, Department of Mechanical Engineering, Eindhoven University of Technology, the Netherlands.

**Were you able to execute the planned experiments?**

YES. We were able to perform all the planned experiments.

**2. Did you encounter experimental problems?**

NO. The setup and the beamline instrumentation were correctly working.

**3. Was the local support adequate?**

YES. The support of the local contact, D. Hermida Merino and of the technical staff, was adequate and allow us to efficiently run the experiments.

#### 4. Are the obtained results at this stage in line with the expected results as mentioned in the project proposal?

YES. All the experimental data collected at BM26-B are used to demonstrate that premature failure of laser sintered PA12 is due to a faster voids formation kinetics than compression moulded PA12. The outcome of the experiments is briefly described below.

##### Experimental

Constant strain rate experiments were performed at 10°C, 24°C (below  $T_g=42^\circ\text{C}$ ) and 120°C at  $5 \cdot 10^{-4} \text{ s}^{-1}$  strain rate by means of a Linkam TST350 tensile stage equipped with a 200 N load cell and a temperature control. The tensile stage was placed in front of the x-ray beam horizontally oriented with respect to x-ray detector (see Figure 1).

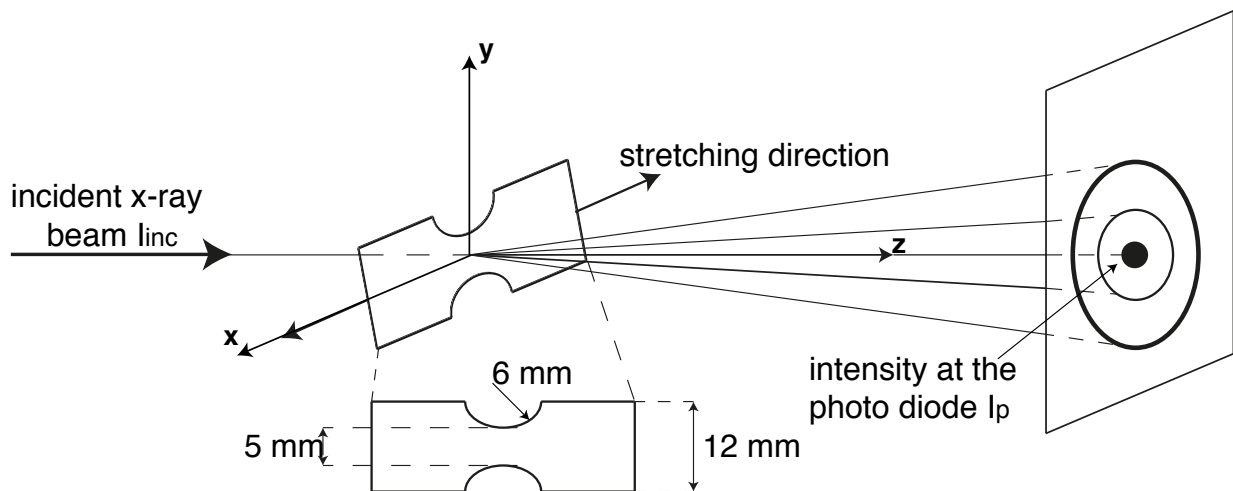

Figure 1. Schematic of the experimental setup together with the dumbbell sample dimensions.

Two sets of experiments were performed:

1. simultaneous Small Angle X-ray Scattering (SAXS) and 1-D Wide Angle X-ray Diffraction (1-D WAXD) patterns were recorded with a Pilatus 1M detector and a Pilatus 3K respectively, with a pixel size of  $172 \times 172 \mu\text{m}$ . The sample to detector distance was 2410 mm for SAXS measurements and 275 mm for the 1-D WAXD measurements.
2. 2-D WAXD patterns were collected with a FReLon 2000 with a pixel size of  $46.3 \mu\text{m}$  and placed at 147 mm from the sample.

For both the two sets of experiments the acquisition time was of 2 seconds and the x-ray wavelength was  $0.9799 \text{ \AA}$ . To correct the diffracted intensity for the actual sample thickness during stretching, the incident beam  $I_{\text{inc}}$  is measured by means of an ionization chamber and the transmitted intensity,  $I_p$ , is recorded with a photo diode.

## Results

Based on our previous work, the mechanical response under constant strain rate of moulded and sintered PA12 is comparable at high temperatures, i.e. temperatures above the glass transition temperature, where inter-lamellar deformation processes are known to be predominant, and becomes larger at temperatures below the glass transition, where intra-lamellar processes contribute more to the stress. For these reason, the tensile test were performed below room temperature, 10, °C at room temperature, 24°C and far above the glass transition, 120°C. As expected, the yield stress as well as the strain at break of moulded PA12 is higher than sintered samples. This behaviour reverses at 120°C where the strain at break is comparable and the yield stress of sintered PA12 is higher than moulded. These results can be explained considering that the higher degree of crystallinity and the thicker lamellae of sintered samples can support higher stress at high temperature but they lead to low stress and brittle failure at low temperatures. Indeed, the SAXS results indicate that cavitation is higher in sintered than moulded PA12 (see Figure 2). This difference in the void fraction reduces when PA12 is tested at high temperature where sintered behaves better than moulded PA12. The SAXS results reveal that moulded and sintered PA12 show two different cavitation processes: in sintered samples, voids originate with their normal parallel to the stretch direction and subsequently elongate and orient with their normal perpendicular to stretching direction. In moulded PA12, voids are formed already oriented with their normal perpendicular to stretch.

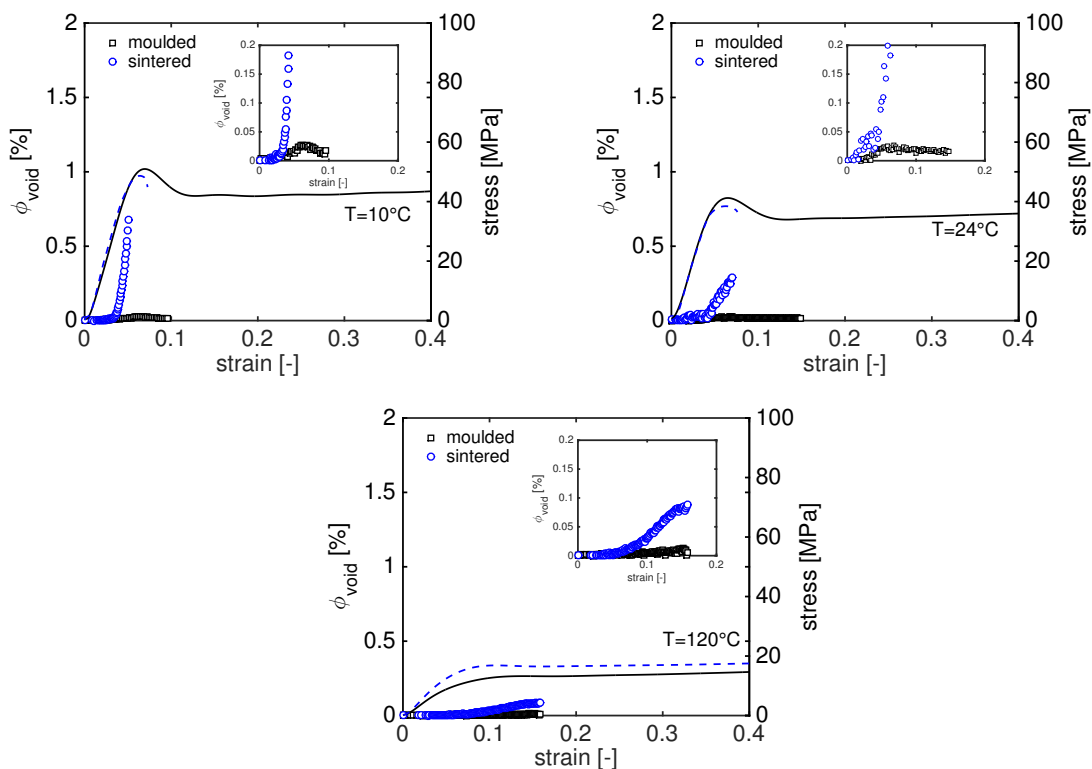

Figure 2. Tensile stress as function of macroscopic strain together with the evolution of void fractions at different testing temperature. The dashed and solid lines represent the stress-strain response of sintered and moulded PA12 respectively; the circles and squares indicate the void fractions for sintered and moulded PA12 respectively.

**5. Are you planning follow-up experiments at DUBBLE for this project?**

NO. The experimental data collected during this experimental session are enough to fully characterize the void evolution of sintered and moulded Polyamide 12.

**6. Are you planning experiments at other synchrotrons in the near future?**

NOT AT THE MOMENT

**7. Do you expect any scientific output from this experimental session (publication, patent ...)**

YES. A scientific outcome (publication) is expected.

**8. Additional remarks**



## **DUBBLE - CLAIM FORM FOR COSTS OF TRAVEL/SUBSISTENCE**

Dutch users of beam time at DUBBLE can use this form to claim full/partial reimbursement of the associated costs of travel and subsistence. The form must be returned to NWO **within 2 months of the completion of the experiment** to [dubble@nwo.nl](mailto:dubble@nwo.nl)

### **Reimbursement rules (costs are reimbursed to the Main Proposer)**

#### **Travel costs**

€ 400 p.p. for max. 3 persons.

#### **Subsistence costs**

Subsistence costs are reimbursed for max. 3 persons @ € 60 p.p. per day (incl. 1 day before the experiment).

---

**Applicant (Main Proposer)** : Gerrit W.M. Peters

Beam time number : 26-02-866

Experiment dates : 3-7/05/2018

#### **Participants** (max 3 persons):

Name : Fabio Paolucci

Name : Prakhyat Hejmady

Name : Jessica Pepe

#### **Payment details**

Pay to account no.: NL42RABO0158249658 (Project Nr. 353000/10018571)

Name: TECHNISCHE UNIVERSITEIT EINDHOVEN

City: Eindhoven